



Quick Reference Guide



Electronic Timer H-series (H3D1, H1D1-X, H1DA-X)

ELECTRONIC AUTOMATION (P) LTD

P. B. # 6414, Yelahanka, Bangalore - 560064

Phones: 0091 - 080 - 8567561/ 8567562

Fax : 080 - 8567129

E-mail : eaplindia@vsnl.com URL : www.eaplindia.com

INTRODUCTION

Thank you for purchasing EAPL'S H-series Timer. This instruction manual describes every aspect of installation, set-up, and operation of the Timer. If you run into difficulties and need technical assistance, feel free to call our technical support at (080) 8567561 available between 9 AM – 5:30PM IST or visit our web site at www.eaplindia.com.

EAPL, an ISO 9001 company, leaders in Timer Technology Brings to you a new range of micro controller based programmable timers. High reliability, accuracy, compactness are some of the striking design features.

Uncompromising quality with cost effectiveness has been the watchword at EAPL.

For Customer Use

Enter below the serial Number which is located on the timer cabinet. Retain this information for future reference.

Model No:

Serial No:

Batch No:

Date of Purchase:

Purchase Point:

Accessories

- H-Series Timer- 1 no.
- Spacer / Side anchor for panel mounting.
- Flat blade screw driver for gear setting & knob lock ring(This is only for H3D1 and H1D1-X)
- Quick reference guide

NOTE: Please acknowledge that we reserve the right to make changes in product performance or specifications without prior notice. Also please note that we bear no responsibility for mistakes, misprints or omissions of the instruction manual Specifications.

Salient Features H3D1

- H3D1 Multi-function timer (On delay / interval/ cyclic on/ cyclic off).
- Din sized (48mm x 48mm) enclosure for Front panel mounting.
- Screw type 8 terminal rear connections.
- Front terminal protective cover for safety. LED indication for timing in progress.
- Large transparent knob for precise time setting.

Salient Features H1D1-X & H1DA-X

- Din sized (48mm x 48mm) enclosure for Panel/Track/Screw mounting.
- 11 pin plug-in type connections.
- Front terminal protective cover for safety. LED indication for timing in progress.
- Large transparent knob for precise time setting.
- H1DA-X accepts any voltage from 12V AC/DC to 220V AC/DC as signal between command contacts.

Ordering Information

Model	Function	Source Voltage	Time Range
H3D1	On delay/interval/cyclic on/cyclic off	240V AC	0.3 secs to 60 mins
H1D1-X	On delay/interval/cyclic on/cyclic off	24V AC to 240V AC & 24V DC to 220V DC	0.3 secs to 60 mins
H1DA-X	Signal OFF delay timer	24V AC to 240V AC & 24V DC to 220V DC	0.6 secs to 60 mins

Specifications For H3D1

Operating Voltage Range	- 15% to + 10% of rated voltage
Rated frequency	50 Hz \pm 5%
Power consumption	AC approx. 15VA / 3W
Control output	2 c/o rated for 5A@ 250V AC/28V DC, Resistive load
Setting Accuracy	\pm 10% max \pm 100msecs w.r.t. Full Scale
Repeat Accuracy	\pm 1% maximum \pm 100ms
Recovery Time	100 mSecs. minimum
Rated frequency of operation	1800/hr \pm 5% max.
Variation due to voltage change	\pm 2% max \pm 100ms
Variation due to temp. change	\pm 5% max \pm 100ms
Variation due to frequency change	\pm 2% max \pm 100ms
Ambient Temperature	Operation: - 10 degree C to + 55 degree C Storage : - 25 degree C to + 80 degree C
Humidity	Max. 85% RH @ 40 degree C
Service Life	10 ⁶ operations minimum under no load
Electrical Life	10 ⁵ Operations minimum with full load
Connections	Screw type terminals with self lifting clamps
Dimensions	48 x 48 x 105 mm (W X H X D)
Range Selection	3s,6s,30s,60s,3min,6min,30min,60min
Insulation Resistance	> 100M ohms@500V DC
Dielectric Strength	a) 2.5KV AC,50Hz for 1minute.(Between current carrying and non-current carrying parts) b) 1.5KV AC, 50Hz for 1 minute.(between contacts and control circuit) c) 1 KV AC, 50 Hz for 1minute.(Between non-continuous relay contacts)

Specifications For H1D1-X & H1DA-X

Operating Voltage Range	- 10% to + 10% of rated voltage
Rated frequency	50 Hz \pm 5%
Allowable ripple for DC	3% maximum
Power consumption	AC approx :3VA / 1W DC approx :2W
Control output	2 c/o rated for 5A@ 250V AC/28V DC, Resistive load
Range Selection	6s,60s,6m,60m for H1DA-X 3s,6s,30s,60s,3m,6m,30m,60m for H1D1-X
Setting Accuracy	\pm 10% max. w.r.t. Full Scale \pm 100msecs
Repeat Accuracy	\pm 1% maximum \pm 100msecs
Recovery Time	100 mSecs. minimum
Rated frequency of operation	1800/hr \pm 5% max
Variation due to voltage change	\pm 2% max. \pm 100msec
Variation due to temp. change	\pm 5% max. \pm 100msec
Variation due to frequency change	\pm 2% max. \pm 100 msecs
Ambient Temperature	Operation: - 10 degree C to + 55 degree C Storage : - 25 degree C to + 80 degree C
Humidity	Max. 85% RH @ 40 degree C
Service Life	10 ⁶ operations minimum under no load
Electrical Life	10 ⁵ Operations minimum with full load
Insulation Resistance	>100M ohms @ 500V DC
Connections	11 pin plug-in-type
Dimensions	48 x 48 x 94 mm [W x H x D]
Start Signal	12 to 240 V AC 50Hz/12 to 220V DC for 150 mS minimum(For H1DA-X only)
Dielectric Strength	a) 2.5KV AC,50Hz for 1minute.(Between current carrying and non-current carrying parts) b) 1.5KV AC, 50Hz for 1 minute.(between contacts and control circuit) c) 1 KV AC, 50 Hz for 1minute.(Between non-continuous relay contacts)

Operating Instructions



Caution

- Set the pointer to the desired graduation of the scale
- Push the knob lock ring as depicted above for correct setting
- Do not change the time range while the timer is in operation.
- Application of voltage other than the specified one will permanently damage the timer.

Front Panel For H3D1

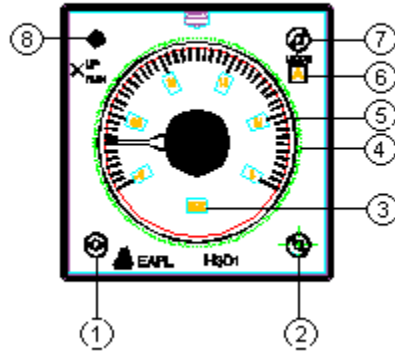

- 1 Gear**
It is provided for selecting the full scale time range (i.e., 0.3 to 60)
- 2 Gear**
It is provided for selecting the desired time range (Sec/Min) .
- 3 Window**
It shows the selected time range (sec/min).
- 4 Knob**
It is provided for setting time for timer.
- 5 Scale**
It is for selected time range.
- 6 Window**
It shows the selected function either 'A' or 'B' or 'C' or 'D'
- 7 Gear**
It is for Selecting the desired function either 'A' or 'B' or 'C' or 'D'.
- 8 Indicator**
It Glows when relay comes ON.
It blinks up to set delay.

Front Panel For H1DA-X

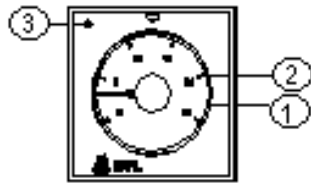

- 1 Knob**
It is used to set the time.
- 2 Scale**
It is for selected time range .
- 3 LED**
It glows when the relay comes on.

Front Panel For H1D1-X

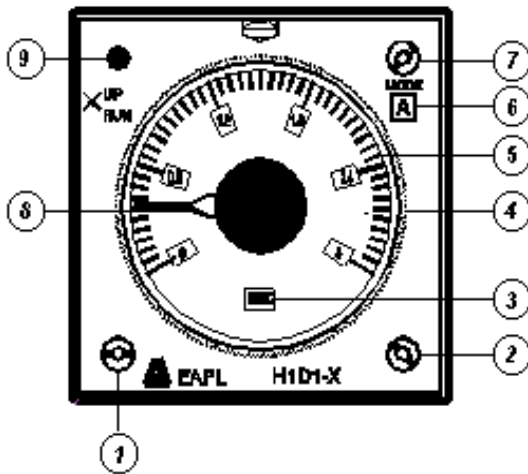

- 1 Knob**
It is provided for setting time for timer.
- 2 Gear**
It is provided for selecting the desired time range (Sec/Min).
- 3 Window**
It shows the selected time range (sec/min).
- 4 Knob**
It is provided for selecting the full scale time range (i.e., 0.3 to 6)
- 5 Scale**
It is for selected time range.
- 6 Window**
It shows the selected function either 'A' or 'B' (Also 'C' or 'D' in the latest version).
- 7 Gear**
It is for Selecting the desired function either 'A' or 'B' (Also 'C' or 'D' in the latest

version).

8 Pointer

It is to select exact timing on the scale.

9 Indicator

It glows when relay comes ON. It blinks up to set delay.

Connection Details

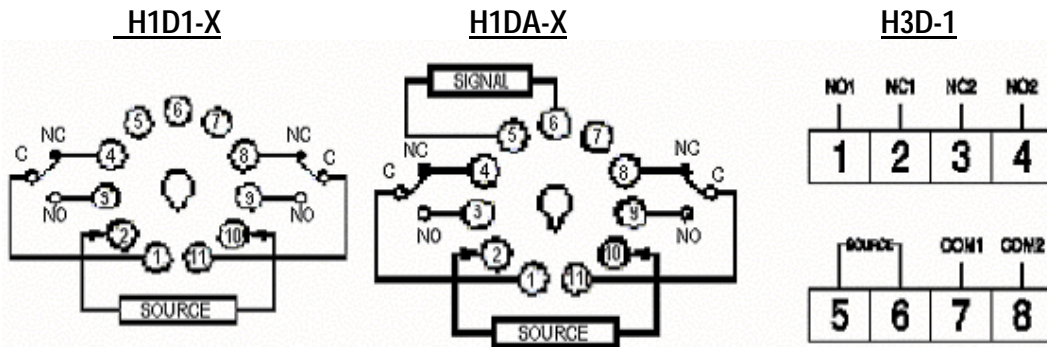

Timing Diagram

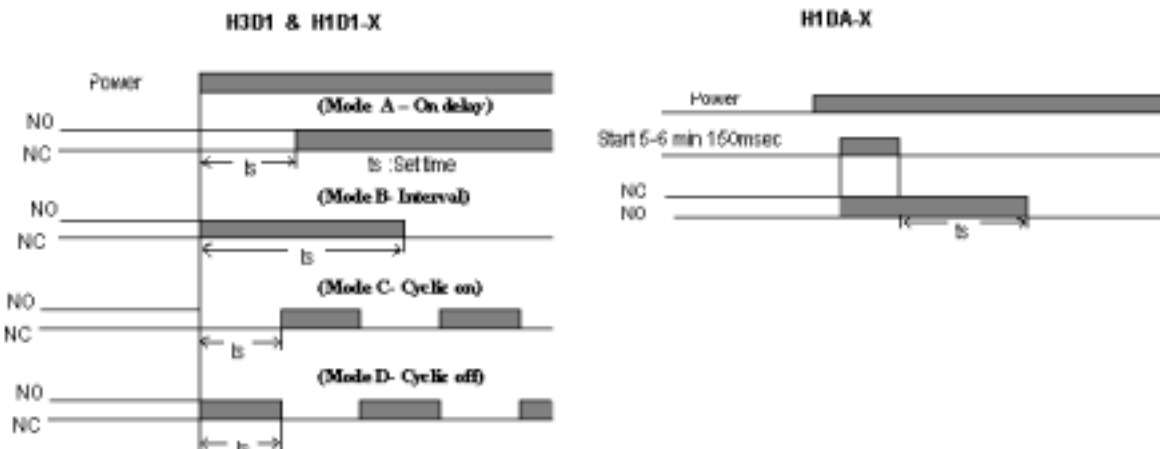

Terminal Details

H3D1

2-7, 3-8 : Normally closed (NC) contacts
1-7, 4-8 : Normally opened (NO) contacts
5, 6 : power

H1DA-X

- 2,10 :power
- 1-4,11-8 :Normally Closed(NC)
- 1-3,11-9 :Normally Opened(NO)
- 5,6 : Start Signal terminal

H1D1-X

- 1-4, 11-8 : Normally closed (NC)
- 1-3, 11-9 : Normally open (NO)
- 2-10 : Power

Dimensions of H1D1-X & H1DA-X

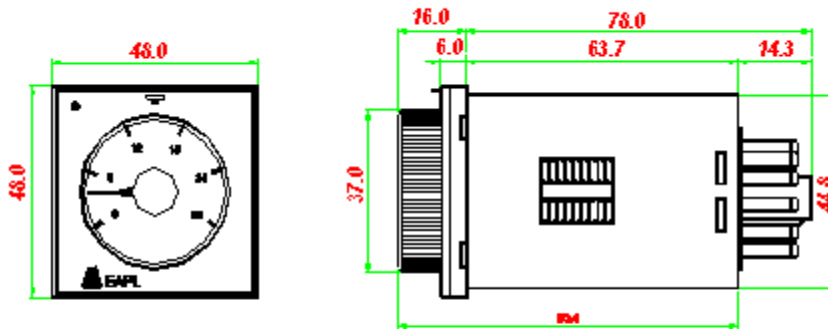

Note :All dimensions are in mm

Dimensions of H3D1

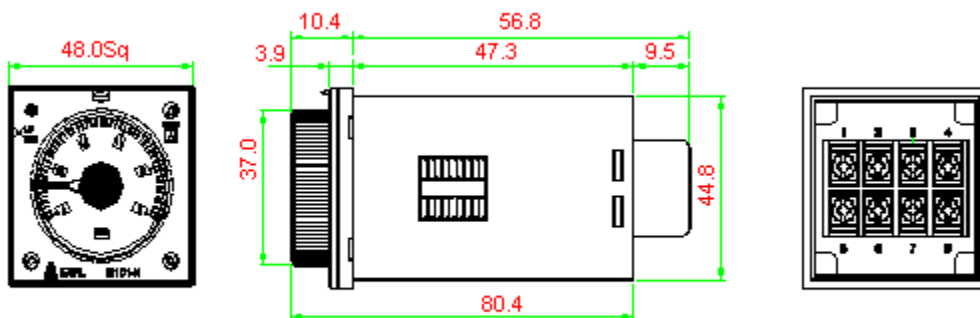

NOTE: ALL DIMENSIONS ARE IN mm

How to select the time range in H3D1

- Select the desired function either ON delay (A)/Interval (B)/Cyclic ON (C)/ Cyclic OFF (D) by rotating the gear provided on the right hand top corner of the front panel (Use the flat blade screw driver provided with the unit). The function selected (A or B or C or D) is displayed on the window provided.
- Now select the desired time range (Sec/Min) by using the flat blade screwdriver by adjusting the gear on the right hand bottom corner. The range selected is displayed on the window provided.
- Similarly select the full-scale time range by rotating the gear provided on left hand bottom corner on the front panel. The full scale selected is displayed on the window provided. For correct setting of function, time range and full scale, refer to the illustration given below.
- Now Rotate the dial to desired position to set the exact timing

How to select the time range H1D1-X

- Select the desired function either 'A' or 'B' (Also 'C' or 'D' in the latest version) by rotating the small gear provided on the right hand top corner on the front panel. The selected mode is displayed in the window.
- Now select the desired time range (Sec/Min) by using the flat blade screwdriver provided with the unit by adjusting the gear on the right hand bottom corner. The selected range is displayed in the window.
- Similarly select the full-scale time range by rotating the gear provided on left-hand bottom corner on the front panel. Selected range is displayed in the window.
- Now refer to the illustration given below for correct setting of mode, time range and full scale.
- Now refer to the illustration given below for correct setting of mode, time range and full scale

ILLUSTRATION

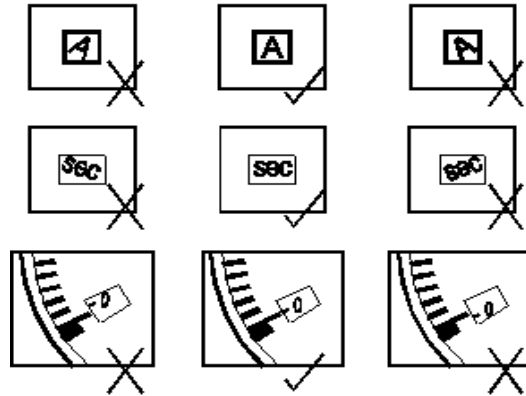

How to select the time range H1DA-X

- While selecting the time range, ensure proper positioning of SEC/MINS within the window cutout. Also ensure proper alignment of full range with respect to markings on the scale.

How to operate the timer H3D1, H1D1-X

- Apply rated voltage to terminal 5 & 6 in case of H3D1, 2&10 in case of H1D1-X on the rear to energize the timer.
- Depending on the function selected the relay contacts changeover accordingly.
- The timer resets on power interruption.

How to operate the timer H1DAX

- Apply rated voltage across terminals 2&10.
- Apply potential signal (12V AC/DC to 240V AC/DC) across command contacts 5, 6. The relays change over.
- However the timing starts when the command contact signal is removed.
- After completion of set time the time relay comes to initial position.

NOTE:

- 1) Use separate cables for source and load from relay contacts
- 2) Do not force the pointer beyond the extremities of the scale.
- 3) Do not change the time range and function during the timing cycle in progress.
- 4) Use the Knob lock ring provided with the unit to lock the dial, after selecting the required timing.