

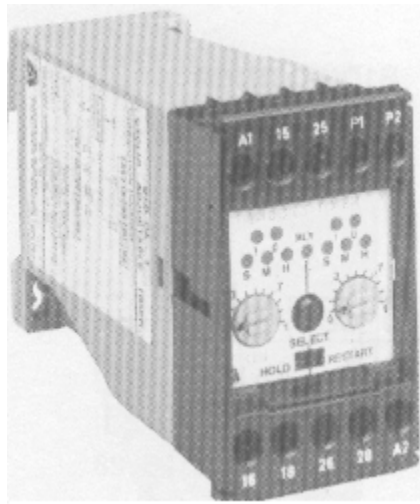

Quick Reference Guide



B Series Timer B1DCA-T

ELECTRONIC AUTOMATION (P) LTD

P. B. # 6414, Yelahanka, Bangalore - 560064

Phones: 0091 - 080 - 8567561/ 8567562

Fax: 080 - 8567129

E-mail : eaplindia@vsnl.com URL : www.eaplindia.com

ISSUE DATE: 15-04-2003

INTRODUCTION

Thank you for purchasing EAPL'S B series B1DCA-T Timer. This instruction manual describes every aspect of installation, set-up, and operation of the B1DCA-T Timer. If you run into difficulties and need technical assistance, feel free to call our technical support at (080) 8567561 available between 9 AM – 5:30PM IST or visit our web site at www.eaplindia.com.

EAPL, an ISO 9001 company, leaders in Timer Technology Brings to you a new range of micro controller based programmable timers. High reliability, accuracy, compactness are some of the striking design features.

Uncompromising quality with cost effectiveness has been the watchword at EAPL.

For Customer Use

Enter below the serial Number which is located on the timer cabinet. Retain this information for future reference.

Model No:

Serial No:

Batch No:

Date of Purchase:

Purchase Point:

Accessories

- B Series B1DCA-T Timer - 1 no.
- Quick reference guide
- Protective Cover

NOTE: Please acknowledge that we reserve the right to make changes in product performance or specifications without prior notice. Also please note that we bear no responsibility for mistakes, misprints or omissions of the instruction manual Specifications.

Salient Features

- Din sized (45mm x 75mm) enclosure for track /screw mounting
- HOLD facility during power fail conditions.
- Programme enable or disable facility for tamper proof operation.
- The time range is from 0.1 secs to 10 hrs in 6 different ranges.
- Front terminal protective cover for safety.
- Independently selectable ON and OFF time.

Ordering Information

Model	Function	Source Voltage	Time Range
B1DCA-T	Cyclic adjustable on-off	240V AC/ 110V AC	0.1 secs to 10 hrs

Special Features

HOLD: When the slide switch on the front panel is kept on the HOLD position, the timing data is retained in case of power failure. Upon resumption of power the timing continues from the point where it had stopped.

RESTART: When the slide switch is kept on the RESTART position, the timer resets in case of power failure and starts from beginning upon power resumption.

PROGRAM ENABLE/DISABLE: To protect the time range selected from being tampered, this feature is provided. By shorting P1 and P2 terminals.[potential free shorting]the time range selection is possible .By removing the short across P1& P2 ,the time range selection is disabled.

Specification

Operating Voltage Range	-15% to + 10% of rated voltage
Rated frequency	50 Hz $\pm 5\%$
Power consumption	AC approximate 5 VA/1W
Control output	2 c/o rated for 5A@250V AC /28 V DC Resistive load
Setting Accuracy	$\pm 10\%$ max. w.r.t. full scale ± 100 msec
Repeat Accuracy	$\pm 1\%$ maximum ± 100 msec
Recovery Time	350 msec minimum
Range Selection	1s,10s,1m,10m,1hr,10hr
Rated frequency of operation	1800 $\pm 5\%$ operations per hour max.
Variation due to voltage change	$\pm 2\%$ max ± 100 msec
Variation due to frequency change	$\pm 2\%$ max ± 100 msec
Variation due to temp. change	$\pm 5\%$ max ± 100 msec
Ambient Temperature	Operating: - 10 degree C to + 55 degree C Storage : - 25 degree C to + 80 degree C
Humidity	Max. 85% RH @ 40 degree C
Service Life (under no load)	10^6 operations minimum
Electrical Life (with full load)	10^5 Operations minimum
Connections	Screw type terminals with self lifting clamps
Insulation Resistance	>100M ohms @ 500 V DC
Dielectric Strength	a)2.5 KV AC ,50HZ for 1 min(between current carrying &non current carrying parts) b)1.5 KV AC,50HZ for 1 min(between contacts and control circuit) c)1 KV AC,50HZ for 1 min(between non continuous relay contacts)
Dimensions	45x 75 x 116 mm [W x H x D]

Operating Instructions



Caution

- Use separate cables to connect A1/A2 & load from relay contacts to avoid timer malfunction.
- Do not change the time range while the timing cycle is in progress.
- Application of voltage other than the specified one will permanently damage the timer

Front Panel

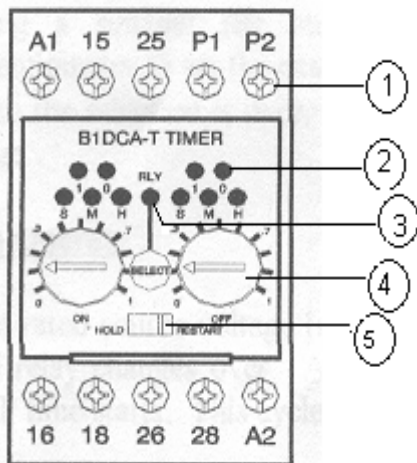

- 1 **TERMINAL SCREW WITH SELF LIFTING CLAMP**
- 2 **LED**
 . This is used for the range selection
- 3 **LED**
 This indicates the relay ON status...
- 4 **KNOB**
 This knob is for the time selection.
- 5 **SWITCH**
 This slide switch is used to select the mode of operation(HOLD/RESTART)

Terminal Details

- A1, A2 : Power
- 15-16, 25-26 : Normally Closed (NC)
- 15-18, 25-28 : Normally Opened (NO)
- P1,P2 : Program Enable/Disable
- * The timer resets on power interruption.

Connection Diagram

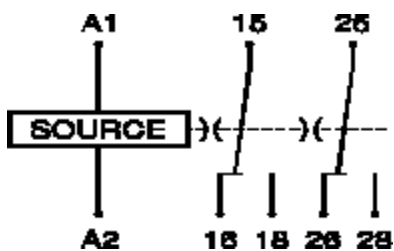

Timing Diagram

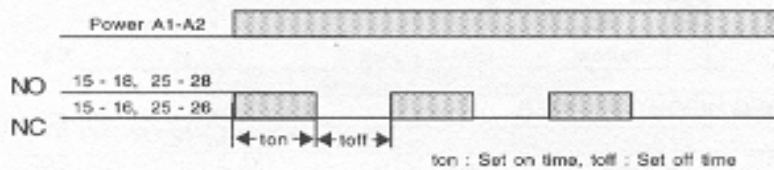

Dimension

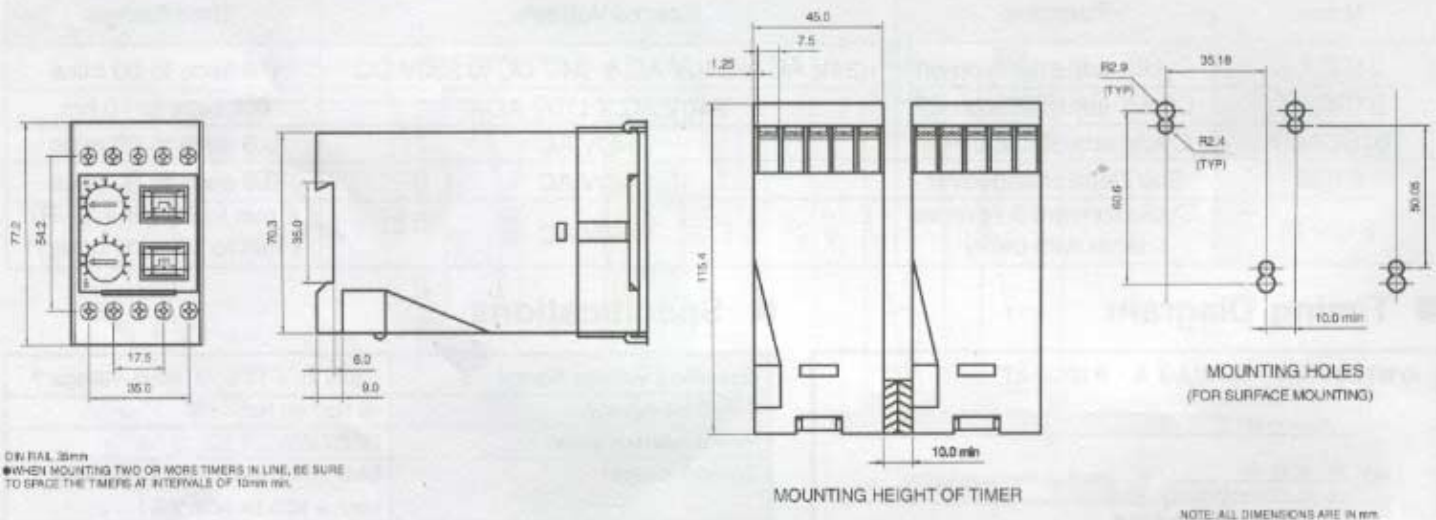

How to select the time range

- Short P1,P2 (potential free shorting)
- Apply the rated source voltage across A1 & A2 (Refer to voltage specifications marked on the timer)
- Press SELECT button & choose the desired "ON & OFF " time range.
- Using a Suitable flat blade screwdriver, rotate the "ON" potentiometer and "OFF" potentiometer to set the exact timing required.
- Once the selection is over, remove the short across P1 & P2 to lock the program for the time range.

How to Operate the timer

- Connect rated source voltage [ref side panel of the timer] across A1 & A2.
- The timer comes ON and relay changes over.
- After the set ON time the relay reverts back to the initial position and off time starts.
- This cycle keeps repeating until the power is interrupted.